

DT 60 DIPTANK



FEATURES:

- Digital temperature control
- Hydraulic movement
- Stainless steel housing
- Optimal hygiene
- Maximal loading capacity: 60 kg
- Machine dimensions: 770 x 790x 1320mm
- Chamber dimensions: 500 x 600 x 220mm
- Dipping depth: 220mm
- Cycle time: 3-5 seconds
- Power: 9,0 kW
- Voltage: 400V-3-50Hz
- Isolation balls prevent evaporation

DESCRIPTION:

Combined with a vacuum packaging machine, DT60 produces perfect skin packages for an aesthetic presentation. Shrink technology protects your product like a second skin. This machine fully complies with CE standards.



DIPTANK — DT 60 — SPEC SHEET



Sales and Service Support

Phone:
(07) 3806 5972

Email:
sales@vacpac.com.au
service@vacpac.com.au

Visit our Showroom

Unit 3, 14-16 Cairns Street,
Loganholme QLD, Australia
4129

DT 60
DIPTANK



DIMENSIONS (IN MM)

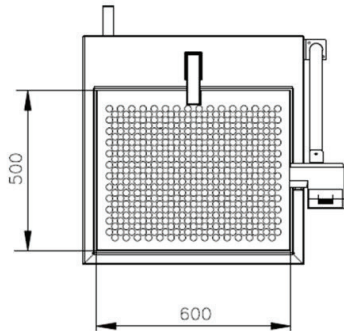

OUTER DIMENSIONS
DT 60

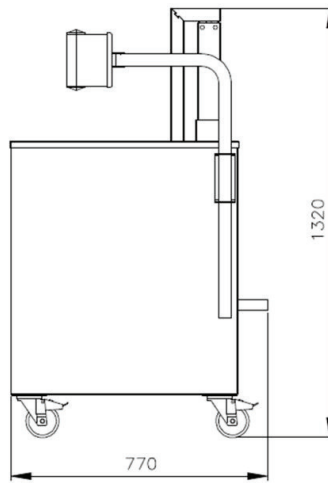
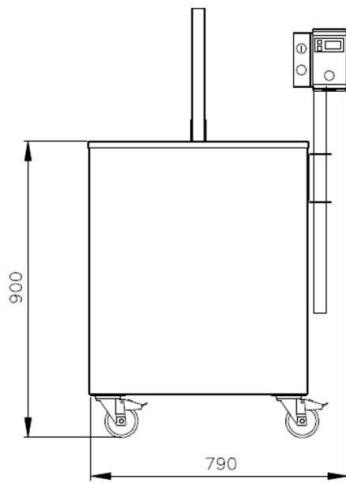

Model	Dimensions (mm)		Voltage* (Hz)	Power (kW)	Weight (kg)
	Chamber (usable space) L x W x H	Machine L x W x H			
Diptank DT 60	500x 600x 220	770x 790x 1320	400V-3-50	9,0	120

* Other voltages available

DIPTANK — DT 60 — SPEC SHEET



Sales and Service Support

Phone:
(07) 3806 5972

Email:
sales@vacpac.com.au
service@vacpac.com.au

Visit our Showroom

Unit 3, 14-16 Cairns Street,
Loganholme QLD, Australia
4129